

TULIP EJECTOR

ES Expulsor Elástico DE Kreuzauswerfer

IT Espulsore Elastico PT Extractor Elástico FR Éjecteur Tulipe

● Cad Insertion Point

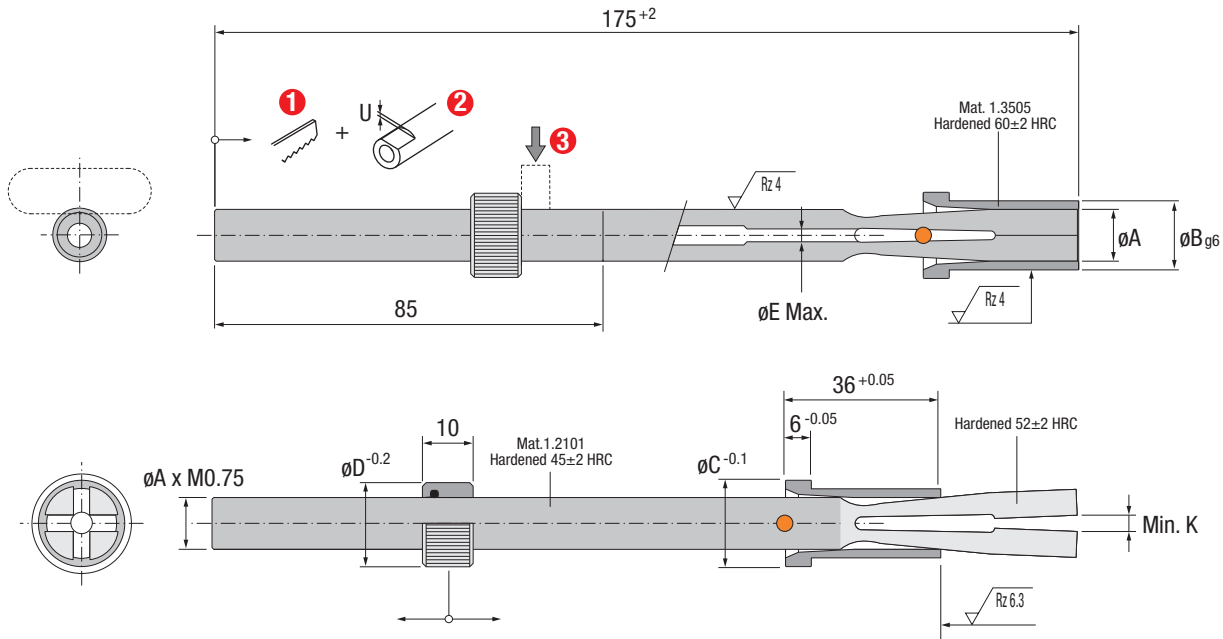

IMPORTANT !
 Special lengths of 250 and 325mm. upon request.
 Largos especiales de 250 y 325mm. bajo demanda.
 Sonderlängen von 250 und 325mm. auf Anfrage.
 Lunghezza speciale 250/325mm. su richiesta.
 Dimensões especiais de 250 e 325mm. quando pedido.
 Longueurs spéciales de 250 et 325mm. sur demande.

Ref.	A	B	C	D	E	H	K	U	Balinit C®
EE.060175	6	10	12	12	-	9	2.8	0.5	●
EE.082175	8	12	14	14	2	11	2.8	0.5	●
EE.103175	10	14	16	16	3	13	2.8	0.5	●
EE.124175	12	16	18	18	4	15	3	0.5	●
EE.168175	16	20	22	22	8	19	3	1	●

Installation Guidelines

Consejos de Instalación · Richtlinien zur Installation · Consigli di Installazione · Instruções de Instalação · Mode d'Installation

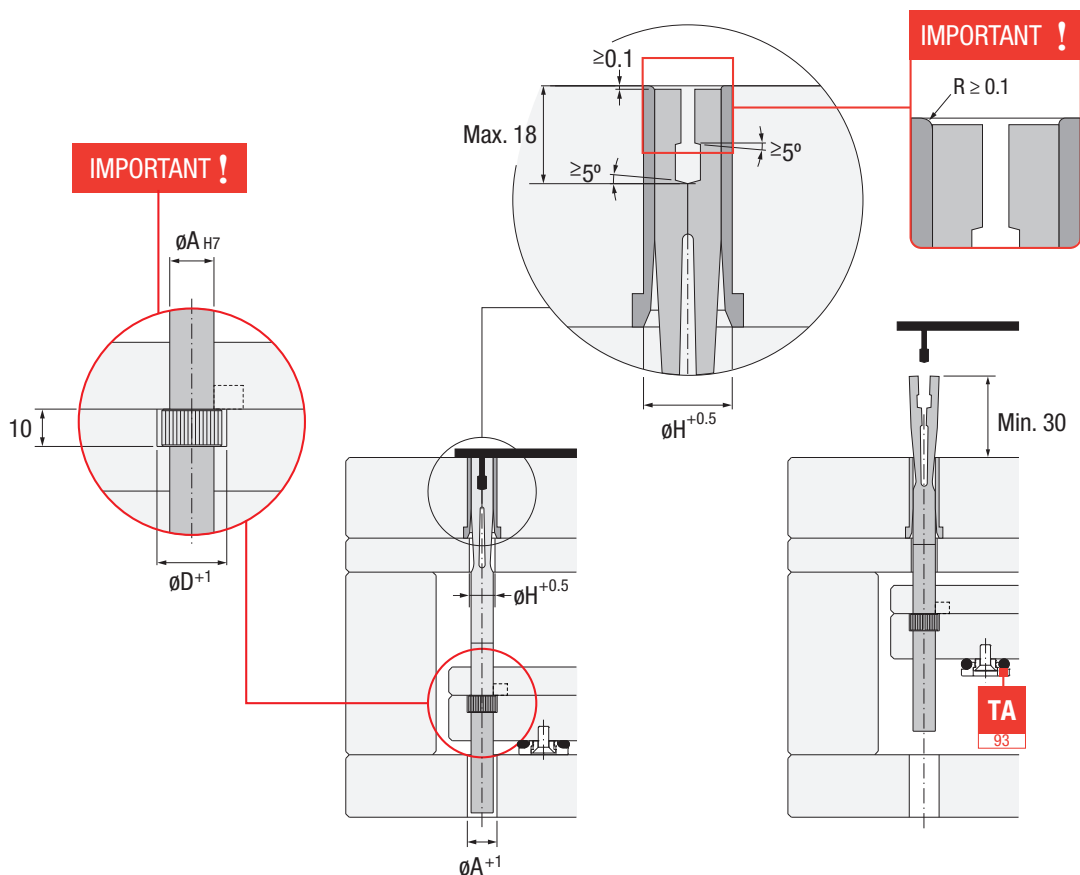

EE

UNDERCUTS



Patented

Max. 150°C