

PH

VACUUM

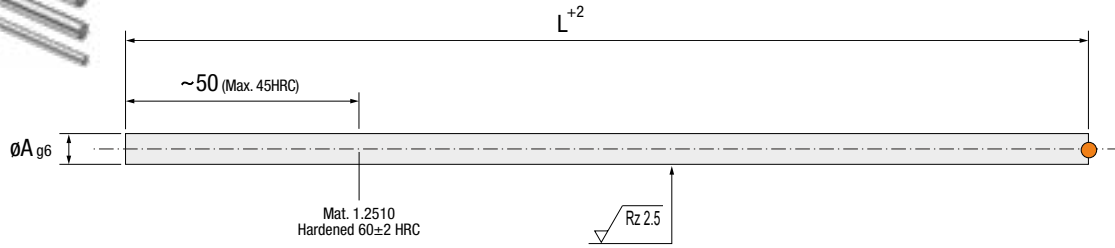

● Cad Insertion Point



Ref.	A	L		
PH.130000-...	3	250	330	500
PH.150000-...	5	250	330	500
PH.160000-...	6	250	330	500
PH.180000-...	8	250	330	500

IMPORTANT !

Indicate the desired **L** dimension after the reference.
Indicar al final de la referencia, la cota **L** deseada.
Gewünschte Länge **L** angeben.
Indicare la quota **L** desiderata alla fine del codice.
Indique o dimensão **L** desejada depois da referência.
Préciser le début de référence et le compléter par la dimension **L** souhaitée.

CV

VACUUM



VACUUMJET PLUG

ES Casquillo Vacuumjet DE Vacuumjet Dichtstopfen
IT Bussola Vacuumjet PT Casquilho Vacuumjet FR Bague Vacuumjet

● Cad Insertion Point

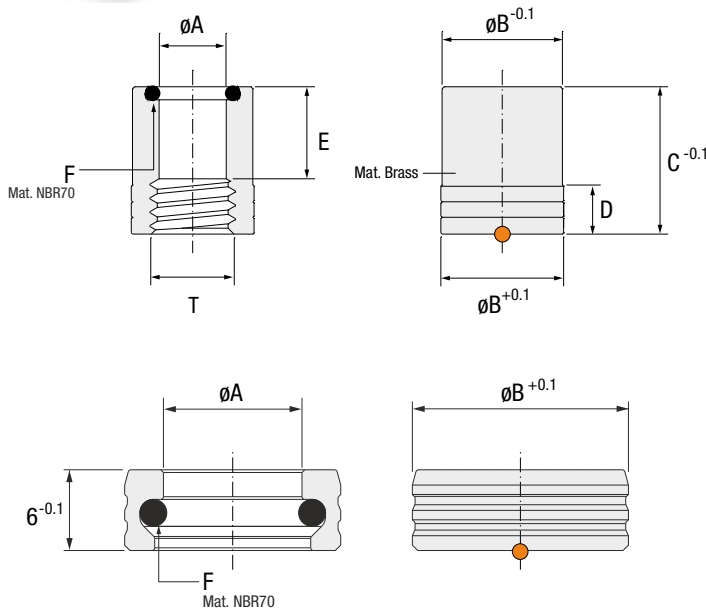

Ref.	A	B	C	D	E	F	T
CV.020812	2	8	12	4.5	8	2x1.5	M3
CV.030812	3	8	12	4.5	8	3x1.5	M4
CV.041012	4	10	12	4.5	8	4x1.5	M5
CV.051012	5	10	12	4.5	8	5x1.5	M6
CV.061212	6	12	12	4.5	8	6x1.5	M8
CV.081416	8	14	16	7	10	8x2	M10
CV.101616	10	16	16	7	10	10x2	M12
CV.121816	12	18	16	7	10	12x2	1/4 GAS

Ref.	A	B	F
CV.142006	14	20	14x2
CV.162206	16	22	16x2
CV.202606	20	26	20x2

Installation Guidelines

Consejos de Instalación · Richtlinien zur Installation · Consigli di Installazione · Instruções de Instalação · Mode d'Installation

