

VG

VACUUM

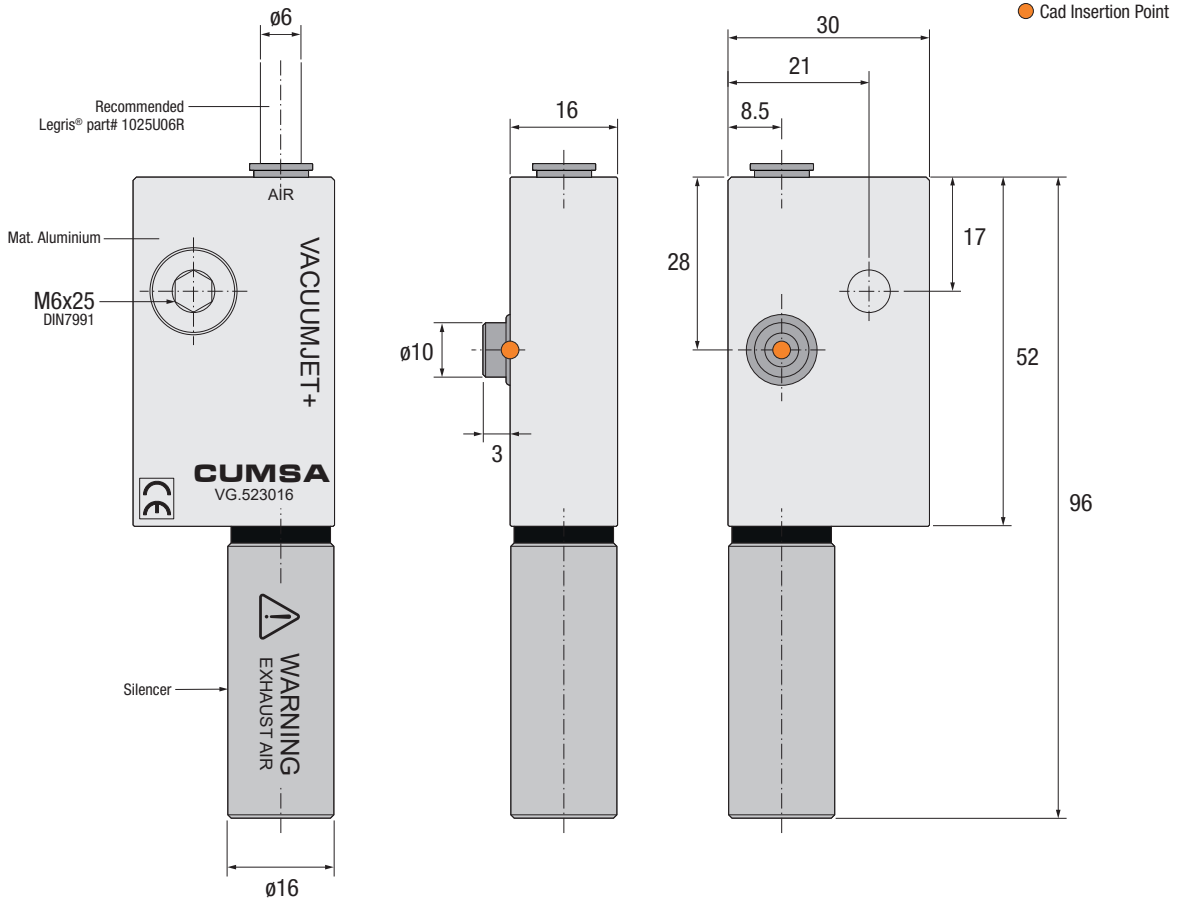

Patented



Ref.	Supply Pressure	Max. Vacuum	Max. Flow	Consumption
VG.523016	5-6 BAR	-900 mbar	75 L./ Min.	60 L./ Min.

**IMPORTANT !** Several units can be connected together in the same Vacuum circuit.  
 En un solo circuito de vacío se pueden conectar varias unidades.  
 Mehrere Einheiten können zusammen im gleichen Vakuumkreislauf angeschlossen werden.  
 In un solo circuito si possono collegare diverse unità.  
 Em apenas um circuito de ar podemos ligar varias unidades.  
 Avec un seul circuit d'air nous pouvons relier plusieurs unités.

Installation Guidelines

Consejos de Instalación · Richtlinien zur Installation · Consigli di Installazione · Instruções de Instalação · Mode d'Installation

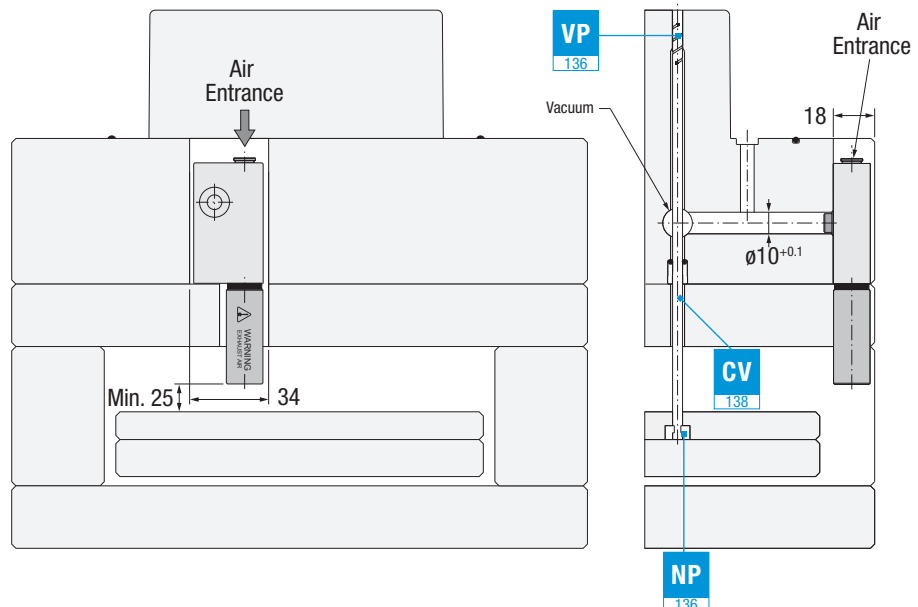

# INSTALLATION GUIDELINES

ES Consejos de Instalación DE Richtlinien zur Installation  
IT Consigli di Installazione PT Instruções de Instalação FR Mode d'Installation



# VG

VACUUM



Vacuum

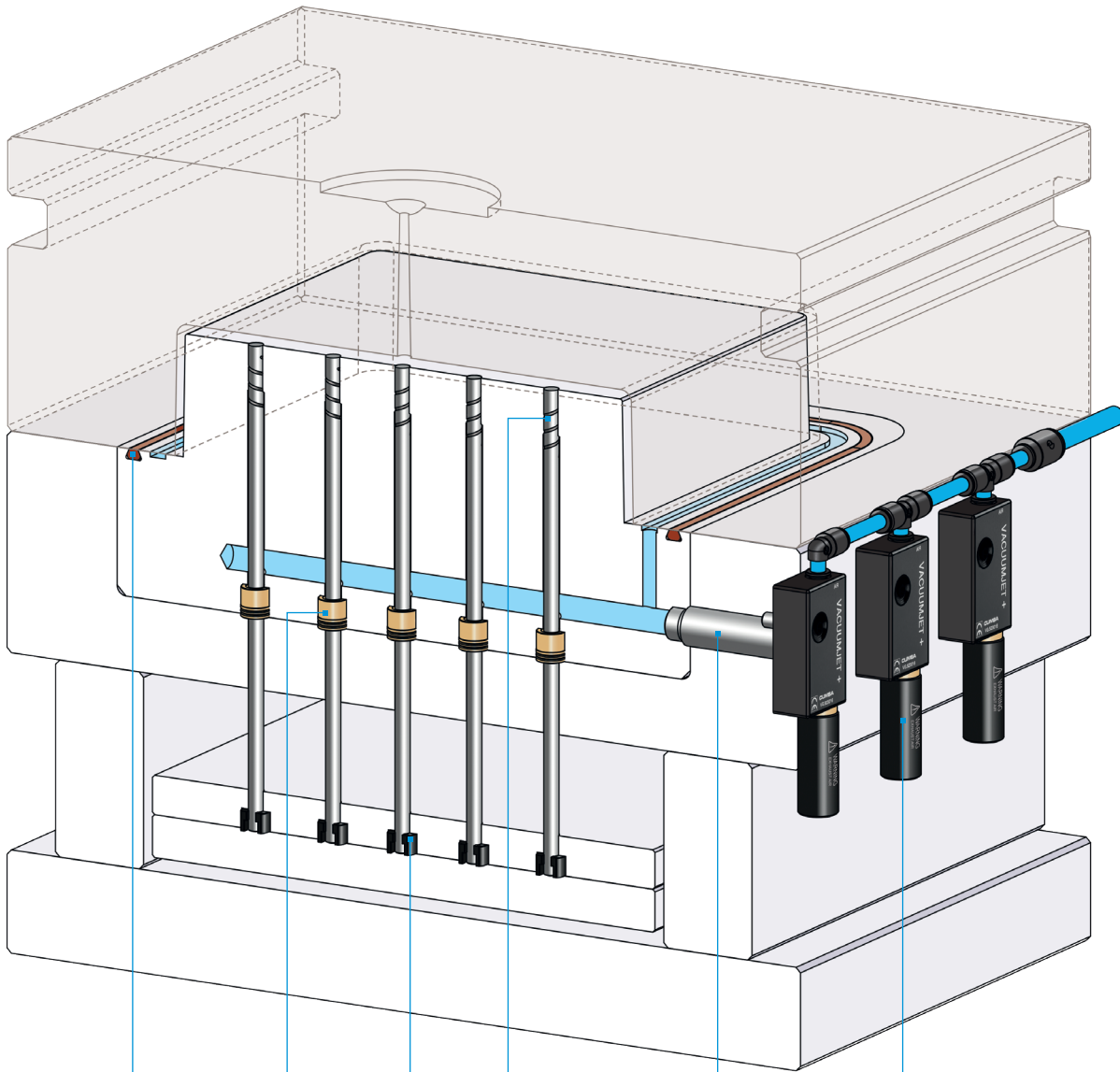

**JV**  
140

**CV**  
138

**NP**  
136

**VP**  
136

**TV**  
140

**VG**  
130